

LED-Profile

COMPACT FLOOR II

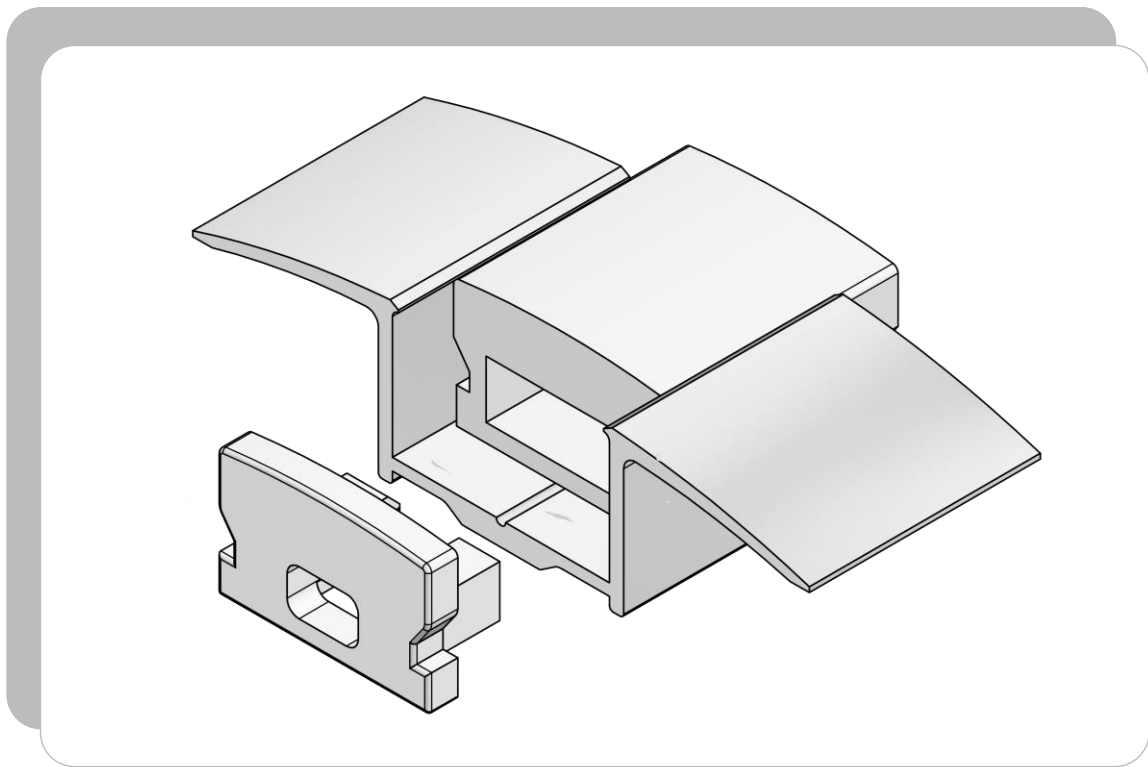
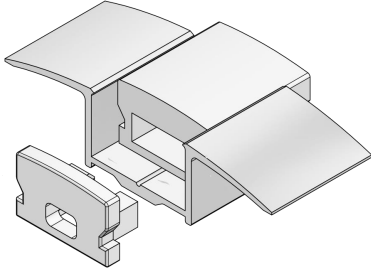
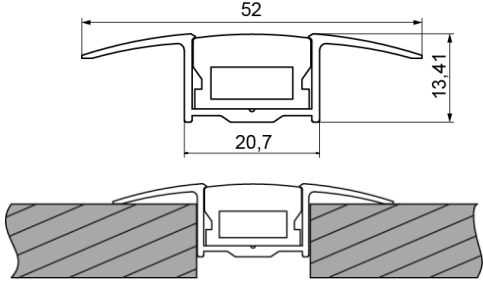

Drees GmbH Sundern / GERMANY	COMPACT FLOOR II 500-408-xxxxx	Kategorie: LED-Profile												
		2023-10-30												
		R006												
														
Aluminiumprofil inkl. opal satiniertem PMMA-Extrusionsprofil und opal satinierten Endkappen Aluminum profile incl. frosted PMMA extrusion profile and frosted end caps		IP67												
Technische Daten / specifications:														
Material material	Aluminium 6063, matt aluminum 6063, matt finished													
	PMMA, opal satiniert PMMA, frosted													
Abmessungen (LxBxH) dimensions (LxWxH)	L x 52 x 13,41mm													
Gewicht / m weight / m	ca. 350g													
Schutzart protection class	IP67*													
Belastbarkeit loading capacity	max. 16kN													
Transmissionsgrad transmittance rate	55%±8% mit Alu- Profil und 70%±8% nur mit PMMA-Profil with aluminum profile with PMMA profile only													
<table border="1" style="width: 100%; border-collapse: collapse;"> <thead> <tr> <th style="text-align: left;">Länge L mm length L mm</th> <th style="text-align: left;">Lieferumfang scope of delivery</th> <th style="text-align: left;">Artikelnummer item number</th> </tr> </thead> <tbody> <tr> <td style="text-align: center;">1000</td> <td>inkl. 2x Endstück incl. 2x end caps</td> <td style="text-align: center;">500-408-01000</td> </tr> <tr> <td style="text-align: center;">2000</td> <td>inkl. 2x Endstück incl. 2x end caps</td> <td style="text-align: center;">500-408-02000</td> </tr> <tr> <td style="text-align: center;">3000</td> <td>inkl. 2x Endstück incl. 2x end caps</td> <td style="text-align: center;">500-408-03000</td> </tr> </tbody> </table>	Länge L mm length L mm	Lieferumfang scope of delivery	Artikelnummer item number	1000	inkl. 2x Endstück incl. 2x end caps	500-408-01000	2000	inkl. 2x Endstück incl. 2x end caps	500-408-02000	3000	inkl. 2x Endstück incl. 2x end caps	500-408-03000		
Länge L mm length L mm	Lieferumfang scope of delivery	Artikelnummer item number												
1000	inkl. 2x Endstück incl. 2x end caps	500-408-01000												
2000	inkl. 2x Endstück incl. 2x end caps	500-408-02000												
3000	inkl. 2x Endstück incl. 2x end caps	500-408-03000												
Zubehör accessories	<table border="1" style="width: 100%; border-collapse: collapse;"> <thead> <tr> <th style="text-align: left;">Zubehörtüte, bestehend aus 2x Endstück (opal satiniert) accessories bag, including 2x frosted end caps</th> <th style="text-align: left;">Artikelnummer item number</th> </tr> </thead> <tbody> <tr> <td></td> <td style="text-align: center;">550-408-99</td> </tr> </tbody> </table>		Zubehörtüte, bestehend aus 2x Endstück (opal satiniert) accessories bag, including 2x frosted end caps	Artikelnummer item number		550-408-99								
Zubehörtüte, bestehend aus 2x Endstück (opal satiniert) accessories bag, including 2x frosted end caps	Artikelnummer item number													
	550-408-99													

*Der Installateur ist für die Einhaltung der IP-Schutzart IP67 verantwortlich. Zur Abdichtung ist 2-Komponenten-Epoxid-Kleber und/oder säurefreies, neutral vernetztes Silikon empfohlen.

*The installer is responsible for the adherence to the degree of protection of IP67. For sealing it is recommended to use 2K Epoxy adhesive and/or acid-free neutrally crosslinking silicone.

Montagehinweis: Aufgrund unterschiedlicher Temperaturkoeffizienten der Materialien Aluminium und PMMA oder PC, sind bei einer Temperaturveränderung von 20°C Ausdehnungsunterschiede von bis zu 1,2mm je Meter möglich.

Assembly instructions: Due to different temperature coefficient of materials aluminum and PMMA or PC, temperature changes of 20°C can cause an expansion difference of up to 1.2mm per meter.