

LED Profile

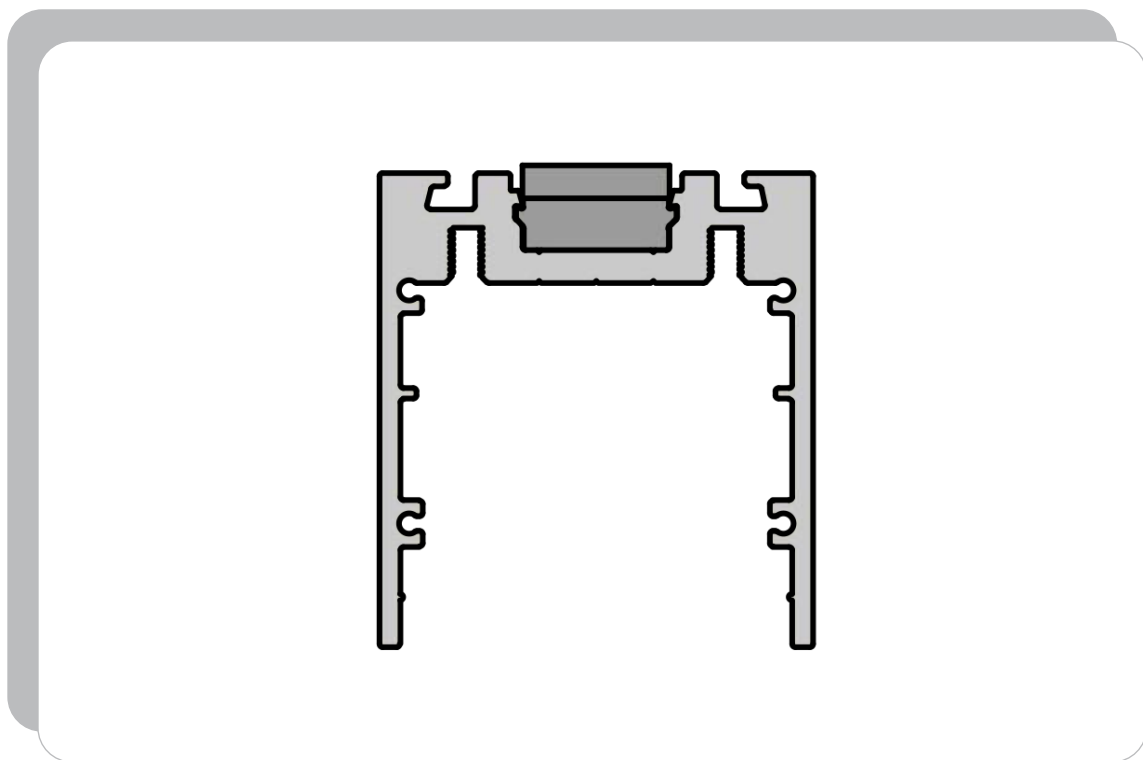

Drees GmbH Sundern / GERMANY	EPIC 550-575-86, 261-506-99	Kategorie: LED Profile				
		28.01.2020				
		R001				
						
<p>EPIC bündige Deckenbefestigung, magnetisch bestehend aus Magnet zum Einschieben in die Profilnut, Halteplatte zur Befestigung mittels zwei Schrauben EPIC flush ceiling mounting, magnetic consisting of magnet to insert into profile groove, retaining plate for assembling with two screws</p>						
<p>Technische Daten / specifications:</p>						
ta	Abmessungen	Gewicht	Material	Montage / Funktion	Bezeichnung	Artikelnr
ta	dimensions	weight	material	installation / function	description	item no.
max. 80°C	(LxBxH) 40x14,6x4,7mm	20g	Neodym N42, vernickelt	Haftkraft max. 3,5kg / 34N	Profilmagnet	550-575-86
-	(LxBxH) 40x13,4x2mm	15g	Stahlblech	2 Schrauben	Halteplatte	261-506-99
<p>Bei der Montage ist eine 5-fache Sicherheit bei der Haftkraft vorzusehen (Leuchtengewicht x5 / Haftkraft des Magneten = Anzahl der Magnete). Aus Sicherheitsgründen ist ein Fangseil an der Leuchte vorzusehen. Die Halteplatten müssen so montiert und zueinander ausgerichtet sein, dass der Magnet 100% Auflagefläche auf der Halteplatte hat, anderenfalls ist die Haftkraft nicht gewährleistet. Die sichere Montage der Leuchte liegt in der Verantwortung des Installateurs!</p> <p>A 5-fold security of the adhesive force must be provided during assembly (luminaire weight x5 / adhesive force of the magnet = number of magnets). A safety rope must be provided on the lamp for safety reasons. The holding plates must be mounted and aligned so that the magnet has 100% contact surface on the holding plate, otherwise the adhesive force is not guaranteed. The installer is responsible for the safe installation of the lamp!</p>						

Zeichnung / drawing:

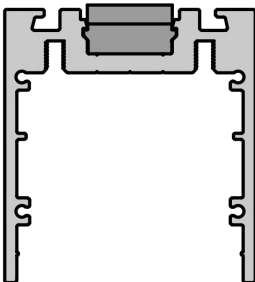
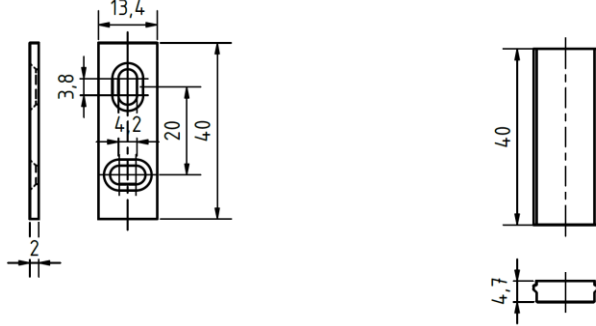